

## Introduction to Regulators

Instrument engineers agree that the simpler a system is the better it is, as long as it provides adequate control. In general, regulators are simpler devices than control valves. Regulators are self-contained, self-operated control devices which use energy from the controlled system to operate whereas control valves require external power sources, transmitting instruments, and control instruments.

### Specific Regulator Types

Within the broad categories of direct-operated and pilot-operated regulators fall virtually all of the general regulator designs, including:

- Pressure reducing regulators
- Backpressure regulators
- Pressure relief valves
- Vacuum regulators and breakers

### Pressure Reducing Regulators

A pressure reducing regulator maintains a desired reduced outlet pressure while providing the required fluid flow to satisfy a downstream demand. The pressure which the regulator maintains is the outlet pressure setting (setpoint) of the regulator.

### Types of Pressure Reducing Regulators

This section describes the various types of regulators. All regulators fit into one of the following two categories:

1. Direct-Operated (also called Self-Operated)
2. Pilot-Operated

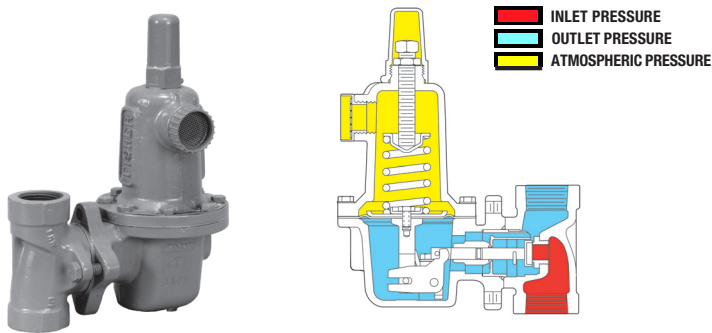

Figure 1. Type 627 Direct-Operated Regulator and Operational Schematic

### Direct-Operated (Self-Operated) Regulators

Direct-operated regulators are the simplest style of regulators. At low set pressures, typically below 1 psig (0,07 bar), they can have very accurate ( $\pm 1\%$ ) control. At high control pressures, up to 500 psig (34.5 bar), 10 to 20% control is typical.

In operation, a direct-operated, pressure reducing regulator senses the downstream pressure through either internal pressure registration or an external control line. This downstream pressure opposes a spring which moves the diaphragm and valve plug to change the size of the flow path through the regulator.

### Pilot-Operated Regulators

Pilot-operated regulators are preferred for high flow rates or where precise pressure control is required. A popular type of pilot-operated system uses two-path control. In two-path control, the main valve diaphragm responds quickly to downstream pressure changes, causing an immediate correction in the main valve plug

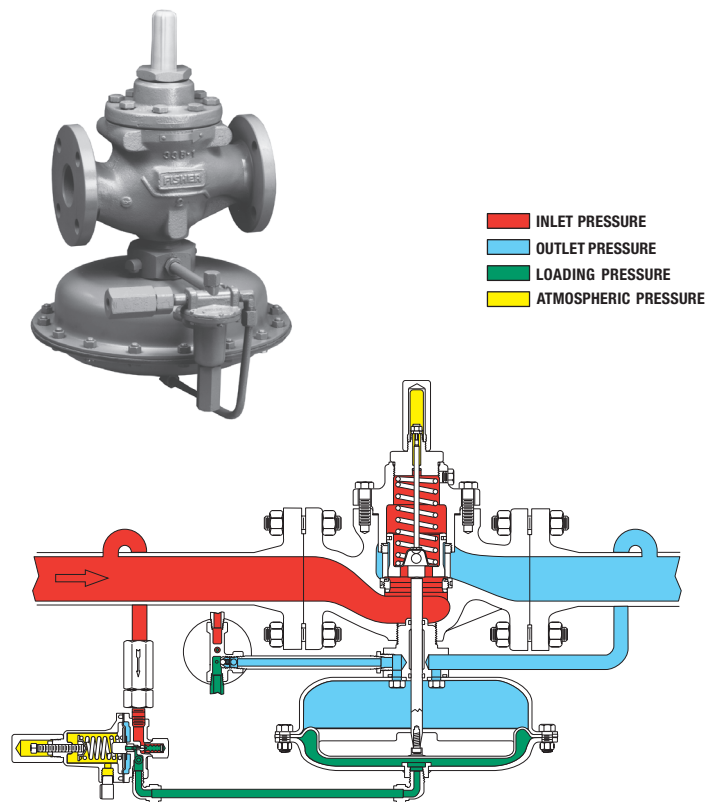

Figure 2. Type 1098-EGR Pilot-Operated Regulator and Operational Schematic

## Introduction to Regulators

position. At the same time, the pilot diaphragm diverts some of the reduced inlet pressure to the other side of the main valve diaphragm to control the final positioning of the main valve plug. Two-path control results in fast response and accurate control.

### Backpressure Regulators and Pressure Relief Valves

A backpressure regulator maintains a desired upstream pressure by varying the flow in response to changes in upstream pressure. A pressure relief valve limits pressure buildup (prevents overpressure) at its location in a pressure system. The relief valve opens to prevent a rise of internal pressure in excess of a specified value. The pressure at which the relief valve begins to open pressure is the relief pressure setting.

Relief valves and backpressure regulators are the same devices. The name is determined by the application. Fisher relief valves are not ASME safety relief valves.

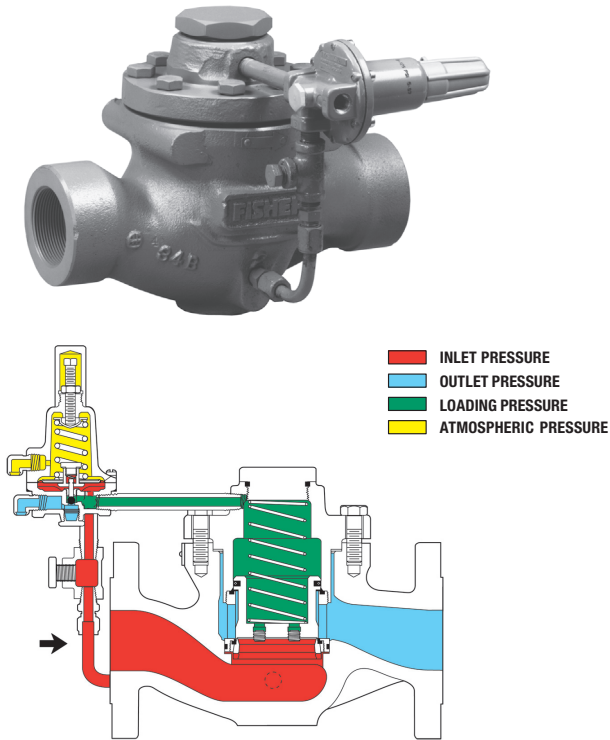
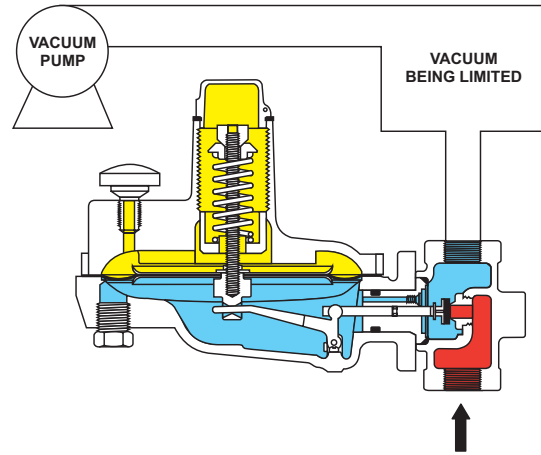

Figure 3. Type 63-EG Backpressure Regulator/Relief Valve and Operational Schematic

### Pressure Switching Valves

Pressure switching valves are used in pneumatic logic systems. These valves are for either two-way or three-way switching. Two way switching valves are used for on/off service in pneumatic systems.

Three-way switching valves direct inlet pressure from one outlet port to another whenever the sensed pressure exceeds or drops below a preset limit.



- INLET PRESSURE
- CONTROL PRESSURE (VACUUM)
- ATMOSPHERIC PRESSURE

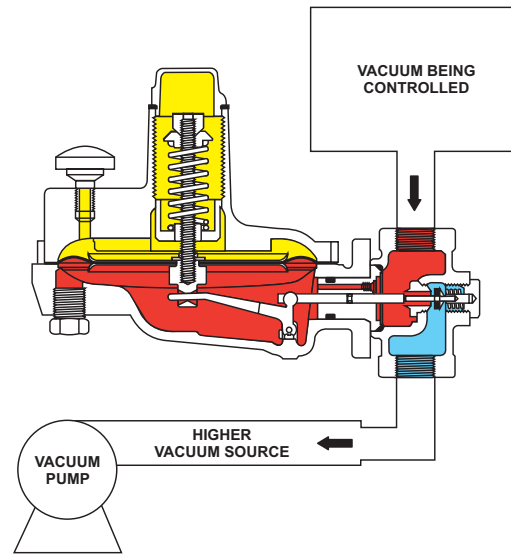

Figure 4. Type Y690VB Vacuum Breaker and Type V695VR Vacuum Regulator Operational Schematics

### Vacuum Regulators and Breakers

Vacuum regulators and vacuum breakers are devices used to control vacuum. A vacuum regulator maintains a constant vacuum at the regulator inlet with a higher vacuum connected to the outlet. During operation, a vacuum regulator remains closed until a vacuum decrease (a rise in absolute pressure) exceeds the spring setting and opens the valve disk. A vacuum breaker prevents a vacuum from exceeding a specified value. During operation, a vacuum breaker remains closed until an increase in vacuum (a decrease in absolute pressure) exceeds the spring setting and opens the valve disk.

## Introduction to Regulators

### Regulator Selection Criteria

This section describes the procedure normally used to select regulators for various applications. For most applications, there is generally a wide choice of regulators that will accomplish the required function. The vendor and the customer, working together, have the task of deciding which of the available regulators is best suited for the job at hand. The selection procedure is essentially a process of elimination wherein the answers to a series of questions narrow the choice down to a specific regulator.

### Control Application

To begin the selection procedure, it's necessary to define what the regulator is going to do. In other words, what is the control application? The answer to this question will determine the general type of regulator required, such as:

- Pressure reducing regulators
- Backpressure regulators
- Pressure relief valves
- Vacuum regulators
- Vacuum breaker

The selection criteria used in selecting each of these general regulator types is described in greater detail in the following subsections.

### Pressure Reducing Regulator Selection

The majority of applications require a pressure reducing regulator. Assuming the application calls for a pressure reducing regulator, the following parameters must be determined:

- Outlet pressure to be controlled
- Inlet pressure to the regulator
- Capacity required
- Shutoff capability required
- Process fluid
- Process fluid temperature
- Accuracy required
- Pipe size required
- End connection style
- Material requirements
- Control line needed
- Overpressure protection

### Outlet Pressure to be Controlled

For a pressure reducing regulator, the first parameter to determine is the required outlet pressure. When the outlet pressure is known, it helps determine:

- Spring requirements
- Casing pressure rating

- Body outlet rating
- Orifice rating and size
- Regulator size

### Inlet Pressure of the Regulator

The next parameter is the inlet pressure. The inlet pressure (minimum and maximum) determines the:

- Pressure rating for the body inlet
- Orifice pressure rating and size
- Main spring (in a pilot-operated regulator)
- Regulator size

If the inlet pressure varies significantly, it can have an effect on:

- Accuracy of the controlled pressure
- Capacity of the regulator
- Regulator style (two-stage or unloading)

### Capacity Required

The required flow capacity influences the following decisions:

- Size of the regulator
- Orifice size
- Style of regulator (direct-operated or pilot-operated)

### Shutoff Capability

The required shutoff capability determines the type of disk material:

- Standard disk materials are nitrile and neoprene, these materials provide the tightest shutoff.
- Other materials, such as nylon, Teflon (TFE), fluoroelastomer (FKM), and ethylenepropylene (EPDM), are used when standard material cannot be used.
- Metal disks are used in high temperatures and when elastomers are not compatible with the process fluid; however, tight shutoff is typically not achieved.

### Process Fluid

Each process fluid has its own set of unique characteristics in terms of its chemical composition, corrosive properties, impurities, flammability, hazardous nature, toxic effect, explosive limits, and molecular structure. In some cases special care must be taken to select the proper materials that will come in contact with the process fluid.

### Process Fluid Temperature

Fluid temperature may determine the materials used in the regulator. Standard regulators use steel and nitrile or neoprene elastomers that are good for a temperature range of -40° to 180°F (-40° to

## Introduction to Regulators

82°C). Temperatures above and below this range may require other materials, such as stainless steel, ethylenepropylene (EPDM), or perfluoroelastomer (FFKM).

### Accuracy Required

The accuracy requirement of the process determines the acceptable droop (also called proportional band or offset). Regulators fall into the following groups as far as droop is concerned:

- **Rough-cut group.** This group generally includes many first-stage, rough-cut direct-operated regulators. This group usually has the highest amount of droop. However, some designs are very accurate, especially the low-pressure gas or air types, such as house service regulators, which incorporate a relatively large diaphragm casing.
- **Close control group.** This group usually includes pilot-operated regulators. They provide high accuracy over a large range of flows. Applications that require close control include these examples:
  - Burner control where the fuel/air ratio is critical to burner efficiency and the gas pressure has a significant effect on the fuel/air ratio
  - Metering devices, such as gas meters, which require constant input pressures to ensure accurate measurement

### Pipe Size Required

If the pipe size is known, it gives the specifier of a new regulator a more defined starting point. If, after making an initial selection of a regulator, the regulator is larger than the pipe size, it usually means that an error has been made either in selecting the pipe size or the regulator, or in determining the original parameters (such as pressure or flow) required for regulator selection. In many cases, the outlet piping needs to be larger than the regulator for the regulator to reach full capacity.

### End Connection Style

In general, the following end connections are available for the indicated regulator sizes:

- Pipe threads or socket weld: 2-inch (DN 50) and smaller
- Flanged: 1-inch (DN 25) and larger
- Butt weld: 1-inch (DN 25) and larger

Note: Not all end connections are available for all regulators.

### Required Materials

The regulator construction materials are generally dictated by the application. Standard materials are:

- Aluminum
- Cast iron or ductile iron
- Steel

- Bronze and brass
- Stainless steel

Special materials required by the process can have an effect on the type of regulator that can be used. Oxygen service, for example, requires special materials, requires special cleaning preparation, and requires that no oil or grease be in the regulator.

### Control Lines

For pressure registration, control lines are connected downstream of a pressure reducing regulator, and upstream of a backpressure regulator. Typically large direct-operated regulators have external control lines, and small direct-operated regulators have internal registration instead of a control line. Most pilot-operated regulators have external control lines, but this should be confirmed for each regulator type considered.

### Stroking Speed

Stroking speed is often an important selection criteria. Direct-operated regulators are very fast, and pilot-operated regulators are slightly slower. Both types are faster than most control valves. When speed is critical, techniques can be used to decrease stroking time.

### Overpressure Protection

The need for overpressure protection should always be considered. Overpressure protection is generally provided by an external relief valve, or in some regulators, by an internal relief valve. Internal relief is an option that you must choose at the time of purchase. The capacity of internal relief is usually limited in comparison with a separate relief valve. Other methods such as shutoff valves or monitor regulators may also be used.

### Regulator Replacement

When a regulator is being selected to replace an existing regulator, the existing regulator can provide the following information:

- Style of regulator
- Size of regulator
- Type number of the regulator
- Special requirements for the regulator, such as downstream pressure sensing through a control line versus internal pressure registration

### Regulator Price

The price of a regulator is only a part of the cost of ownership. Additional costs include installation and maintenance. In selecting a regulator, you should consider all of the costs that will accrue over the life of the regulator. The regulator with a low initial cost may not be the most economical in the long run. For example, a direct-operated regulator is generally less expensive, but a pilot-operated

## Introduction to Regulators

regulator may provide more capacity per dollar. To illustrate, a 2-inch (DN 50) pilot-operated regulator can have the same capacity and a lower price than a 3-inch (DN 80), direct-operated regulator.

### Backpressure Regulator Selection

Backpressure regulators control the inlet pressure rather than the outlet pressure. The selection criteria for a backpressure regulator the same as for a pressure reducing regulator.

### Relief Valve Selection

An external relief valve is a form of backpressure regulator. A relief valve opens when the inlet pressure exceeds a set value. Relief is generally to atmosphere. The selection criteria is the same as for a pressure reducing regulator.

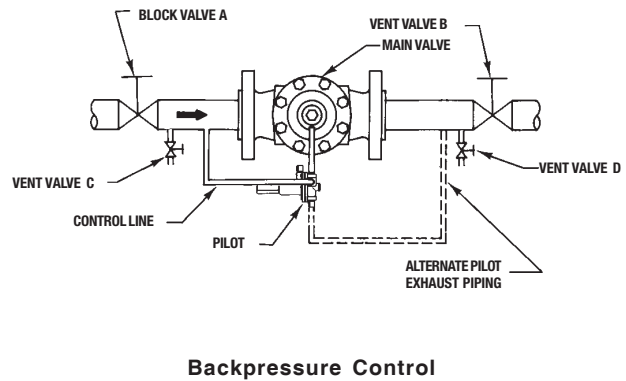
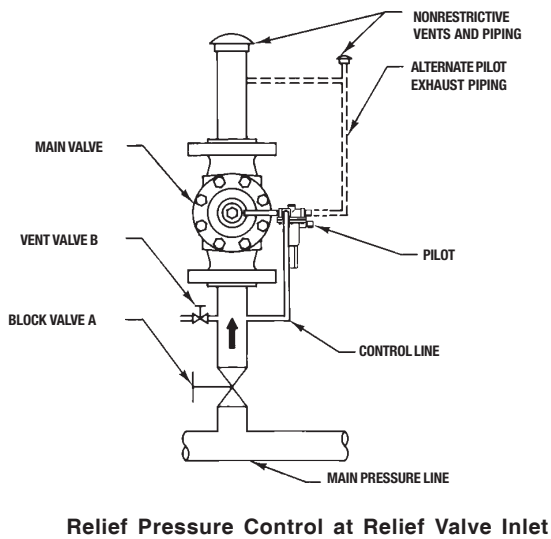

Figure 5. Backpressure Regulator/Relief Valve Applications